

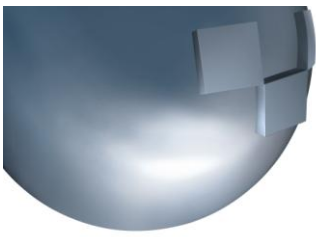

# **FAST COMMUTATOR CF**

## **INSTRUCTION MANUAL 2073**





Date	Revision	Description	Compiled	Approved
04/04/2014	0	Issue	N.Zenoni	F.Tondolo

*STI S.r.l has taken every care in collecting and verifying the documentation contained in this Instruction Manual. The information herein contained are reserved property of STI S.r.l.*

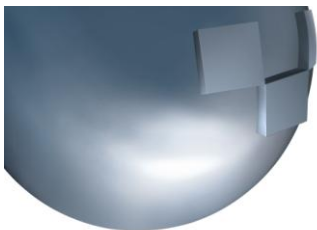

## INDEX

<b>1</b>	<b>GENERAL INFORMATIONS</b>	<b>1</b>
1.1	GENERAL WARNINGS	1
1.2	GENERALITIES	1
1.3	MANUFACTURER	1
1.4	TERMS AND CONDITIONS	1
1.5	MANUFACTURER'S LIABILITY	1
1.6	APPLICABLE STANDARDS AND DIRECTIVES	2
1.7	SYMBOLGY USED	2
<b>2</b>	<b>DEVICE DESCRIPTION</b>	<b>3</b>
<b>3</b>	<b>TECHNICAL DATA</b>	<b>3</b>
<b>4</b>	<b>LABEL</b>	<b>4</b>
<b>5</b>	<b>INSTALLATION</b>	<b>5</b>
5.1	TRANSPORT	5
5.2	RECEPTION	5
5.3	STORAGE	5
5.4	REQUIREMENTS OF STABILITY	5
5.5	DOCUMENTS AND DIMENSIONAL DRAWINGS	5
5.6	INSTALLATION	6
5.7	DISASSEMBLING	7
<b>6</b>	<b>OPERATION AND USE</b>	<b>8</b>
6.1	OPERATION DESCRIPTION	8
6.2	INTENDED USE	9
6.3	REASONABLY FORESEEABLE MISUSE	10
6.4	OPERATING LIMITS	10
6.5	RESIDUAL RISKS	10
<b>7</b>	<b>INSTRUCTIONS FOR THE OPERATOR</b>	<b>10</b>
<b>8</b>	<b>MAINTENANCE</b>	<b>11</b>
8.1	PERIODIC INSPECTIONS	11
8.2	SPECIAL MAINTENANCE	11
8.3	REPAIRS	11
8.4	REASSEMBLING	11
8.5	MECHANISM LUBRICATION	11
<b>9</b>	<b>PARTS LIST GENERAL ASSEMBLY</b>	<b>12</b>
9.1	CF ASSEMBLY	12
<b>10</b>	<b>TROUBLESHOOTING</b>	<b>14</b>
<b>11</b>	<b>SPARE PARTS</b>	<b>14</b>
<b>12</b>	<b>DECOMMISSIONING</b>	<b>14</b>

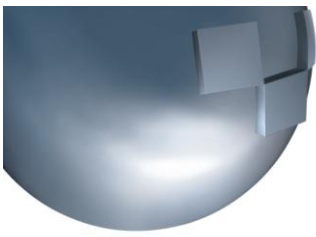

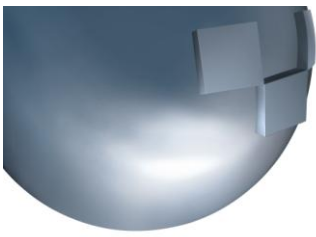

# 1 GENERAL INFORMATIONS

## 1.1 General Warnings

<b>Important</b> 	<p><b>This Instruction Manual is an integral part of the machine, it should be carefully read before carrying out any operation and it should be kept for future references. The operators shall adopt the safety precautions required by the country where the product is installed.</b></p> <p><b>This Instruction Manual is realized in accordance with the Directive 2006/42/CE.</b></p>
---	--

## 1.2 Generalities

STI S.r.l. accessory are conceived, manufactured and controlled according to the Quality Control System in compliance with EN ISO 9001 International Standard.

## 1.3 Manufacturer

With respect to Machinery Directive 2006/42/EC, the Manufacturer of the described CF Fast Commutator is STI S.r.l. as specified on the label.

STI S.r.l. Via Pascoli 10 a/b  
24020 Gorle (BG) Italy  
Tel. +39 035 2928.2  
Fax +39 035 2928.247  
[info@stistrumentazione.com](mailto:info@stistrumentazione.com)

## 1.4 Terms and conditions

STI S.r.l. guarantees each single product to be free from defects and to conform to current goods specifications. The warranty period is one year from the date of installation by the first user, or eighteen months from the date of shipment to the first user, whichever occurs first.

The warranty does not cover special products or components not covered by warranty in their turn by subcontractors. No warranty is given for products which have been subject to improper storage, improper installation, misuse, corrosion, or which have been modified or repaired by unauthorised personnel: it is not advisable that customer or end users modify the device characteristics.

## 1.5 Manufacturer's Liability

STI S.r.l. declines all liability in the event of:

- use of the CF in contravention of local safety at work legislation;
- incorrect installation, disregard or incorrect application of the instructions provided on the CF label and in this manual;
- modifications without STI's authorisation;
- work done on the unit by unqualified or unsuitable persons.

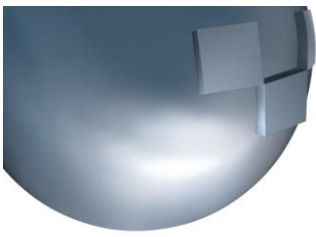

## 1.6 Applicable Standards and Directives

- EN ISO 12100:2010 Safety of machinery - General principles for design;
- IEC 61508:2010 Functional Safety of Electrical/Electronic/Programmable Electronic Safety-related Systems;
- 2006/42/EC Machinery Directive;
- 97/23/EC Pressure Equipments Directive (PED);
- 94/9/CE Equipments used in potentially explosive atmospheres (ATEX).

## 1.7 Symbology Used

### 1.7.1 Signs of warning

Be careful where these symbols are shown, they indicate a potentially hazardous situation and they warn that if the steps are not properly performed, **MAY RESULT CAUSING** serious injury, death or long-term risks to the health of exposed persons.



GENERAL DANGER



DANGER POWER SUPPLY



CRUSHING HAZARD

### 1.7.2 Signs of obligation



General obligation (with the possible supplementary signboard)



Must wear protective clothing.



Obligation to wear protective footwear.



Is required to wear a helmet.



Is required to protect the eyes.



Obligation to protect your hearing.

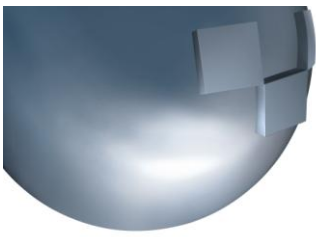

## 2 DEVICE DESCRIPTION

The CF is constituted by two 3-way valves having the pilot conduit in common. This accessory is designed to operate with a pilot pressure greater than 2 bar, still maintaining a perfect seal on the seats up to 8 bar. Since the pilot fluid goes to work on moving a single membrane, the switching will be also very fast.

## 3 TECHNICAL DATA

Model	Technical features			
	Type A	Type B	Type C	Type D
Housing material	Aluminum	Aluminum	Stainless steel	Stainless steel
Feeding	With pilot	Without pilot	With pilot	Without pilot
Feeding connections	See the following table	See the following table	See the following table	See the following table
Outlet connections	See the following table	See the following table	See the following table	See the following table
Signal connections	1/4" NPTF	1/4" NPTF	1/4" NPTF	1/4" NPTF
Operating temperature range	-60/+100 °C	-60/+100 °C	-60/+100 °C	-60/+100 °C
Design pressure	10 bar	10 bar	10 bar	10 bar
Operating pressure range	See label	See label	See label	See label
Expected lifetime	20 years	20 years	20 years	20 years

Model	To actuator			To positioner		
	1/2" NPTF	1/2" NPTF	3/4" NPTF	PLUG-IN	PLUG-IN	PLUG-IN
A/B/C/D	3/4" NPTF	3/4" NPTF	3/4" NPTF	PLUG-IN	PLUG-IN	PLUG-IN
A/B/C/D	3/4" NPTF	3/4" NPTF	3/4" NPTF	3/4" NPT	3/4" NPT	3/4" NPT



Figure 1 – Fast Commutator CF

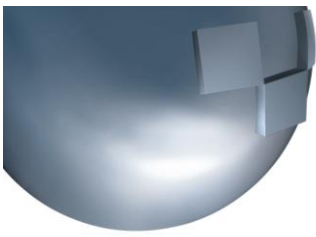

## 4 LABEL

The plate fastened on the CF contains the main operating conditions. The supply can be instrument air or natural gas. It is forbidden to modify the information and the marks without previous written authorization by STI S.r.l.

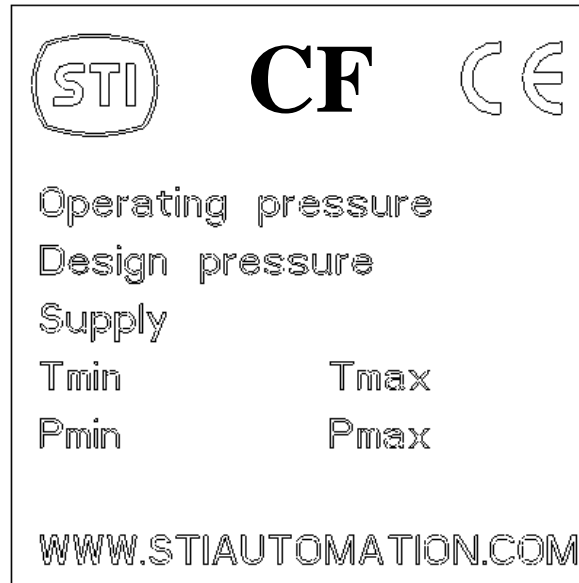
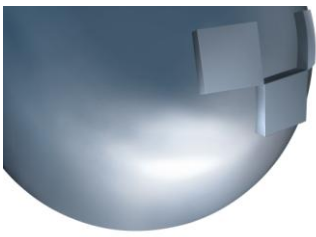



Figure 2 – label





## 5 INSTALLATION

<b>Important</b> 	<b>Not performing the following procedures will invalidate the product guarantee.</b>
---	---

### 5.1 Transport

<b>Important</b> 	<b>The lifting and handling should be made by qualified staff and in compliance with the laws and provisions in force.</b>
---	--

### 5.2 Reception

Check that the model correspond with that of order confirmation.

Check that the CF was not damaged during transportation: if necessary renovate the painting according to the specification reported on the order confirmation.

### 5.3 Storage

Fast Commutators leave the factory in perfect condition. Performances of each unit are guaranteed by tests and data reported on a specific Test Report. In order to maintain these characteristics until the CF is installed on site, proper attention must be observed for preservation during the storage period.

If the CF needs storage, before installation follow these steps:

- place it on a wood surface pallet or on metallic support, so that they are not in direct contact with the ground, or packed with appropriate covering;
- make sure that plastic plugs are present on the pneumatic connections (if present).

If the storage is long-term or outdoor:

- keep the CF protected from direct weather conditions;
- replace plastic plugs of pneumatic connections (if any) with metal plugs that guarantee perfect tightness.

### 5.4 Requirements of Stability

Concerning the requirement of stability during installation and disassembling it's possible to refer to the next chapters 5.6 and 5.7.

### 5.5 Documents and dimensional drawings

Pneumatic diagrams, wiring diagrams and dimensional drawings are furnished with document accompanying the actuator.

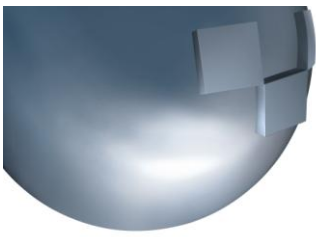

## 5.6 Installation

<b>Warning</b> 	<p>Before proceeding with any Installation the following instructions must be respected:</p> <ul style="list-style-type: none"><li>- Always wear protective clothing, gloves, and eyewear to prevent personal injury;</li><li>- Check with your process or safety engineer for any additional measures that must be taken to protect against process media.</li></ul>
---	---

### 5.6.1 Checks to be performed before installation

- Check that the coupling dimensions meet the specified coupling dimensions.
- Prepare the necessary tools for the assembly and setting of the unit.
- Check that the outer surface of the CF is free from dust and dirt.
- Clean the CF surfaces and remove anything that might prevent a perfect adherence.

### 5.6.2 Assembling of the CF

Threading	Material	Tightening torque [Nm]
M6	8.8	15
	A4-70	10

### 5.6.3 Pneumatic connections

<b>Warning</b> 	<p>Check that the values of pneumatic supply available are compatible with those reported on the identification plate of the CF. Use pipes and connections appropriate as for type, rating, material and dimensions. The connection should be made by qualified staff.</p>
---	--

- Properly deburr the ends of rigid pipes.
- Properly clean the interior of pipes sending through them plenty of the supply fluid used in the system.
- Mould and fasten the connection pipes so that no irregular strains at entries or loosening of threaded connections occur.
- Use pipe sealant sparingly and only on male threads. A non-hardening sealant is strongly recommended.
- Make the connections according to the operating diagram.
- Check the absence of leakages from pneumatic connections. If necessary tighten the nuts of the pipe-fittings.

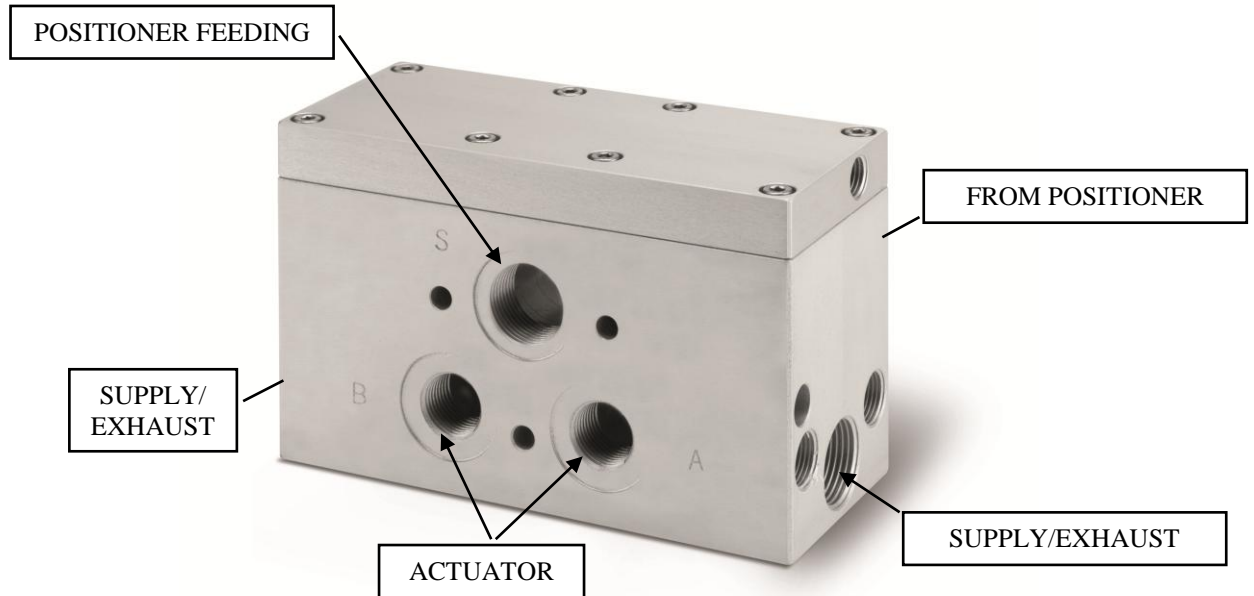
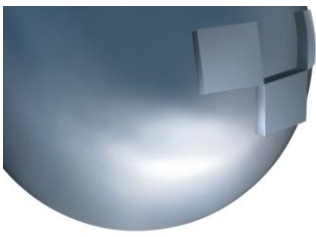

Figure 3 – pneumatic connections

#### 5.6.4 Earting connection

The earting connection is guaranteed trough the fixing screws of the CF. If the earting connection of the system where CF is mounted is not guaranteed, it is necessary ensure a directly earting connection from the screws.

### 5.7 Disassembling

#### Warning



Before starting the disassembly operations it is mandatory to disconnect the pneumatic power and to exhaust the CF. Cylinders chambers, pipe fittings and accessories must not be under pressure. The staff must be qualified for the required operation.

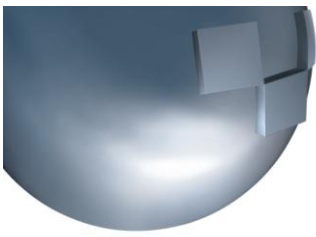

## 6 OPERATION AND USE

### 6.1 Operation description

The CF has 2 main setups: energized and not energized.

Figure 4 shows the energized setup: for each 3-way valve, the working fluid passes through the diaphragm plugger and pushes down the piston. The shutter stem blocks the connection between the CF supply/exhaust chamber and the actuator chamber and allows the connection between the positioner and the actuator chamber.

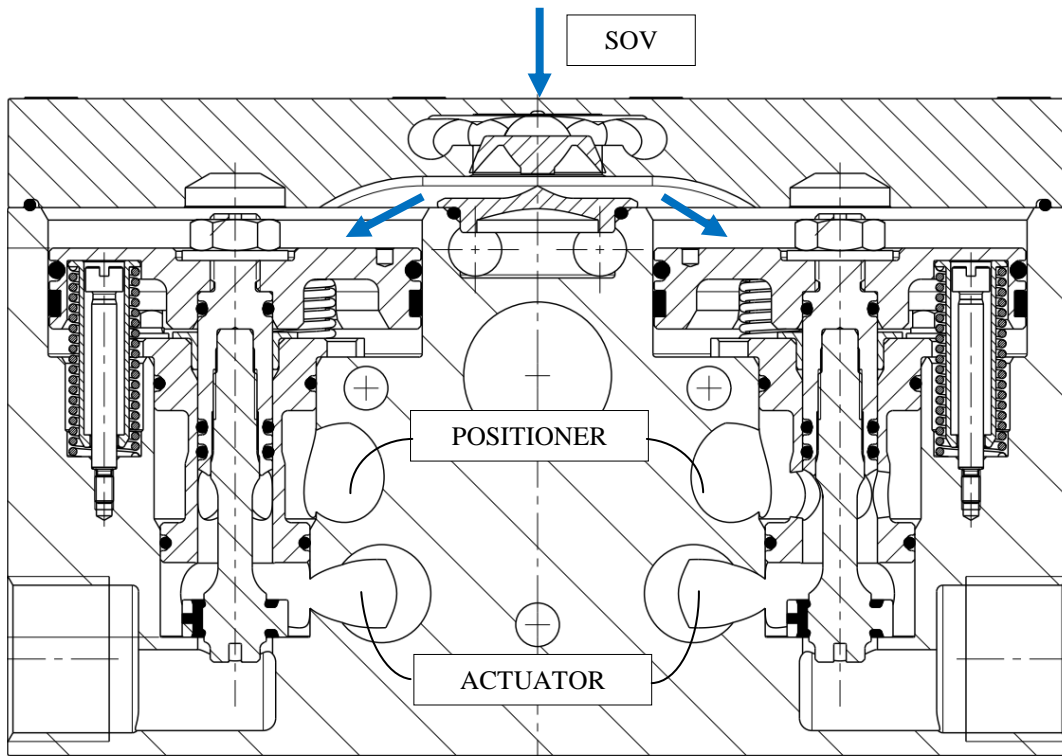

Figure 4 - energized setup

Figure 5 shows the not energized setup: for each 3-way valve, the springs push up the piston and the working fluid passes from the chamber above the piston to the environment. In this position the shutter stem allows the connection between the CF supply/exhaust chamber and the actuator chamber (supply mode or exhaust mode).

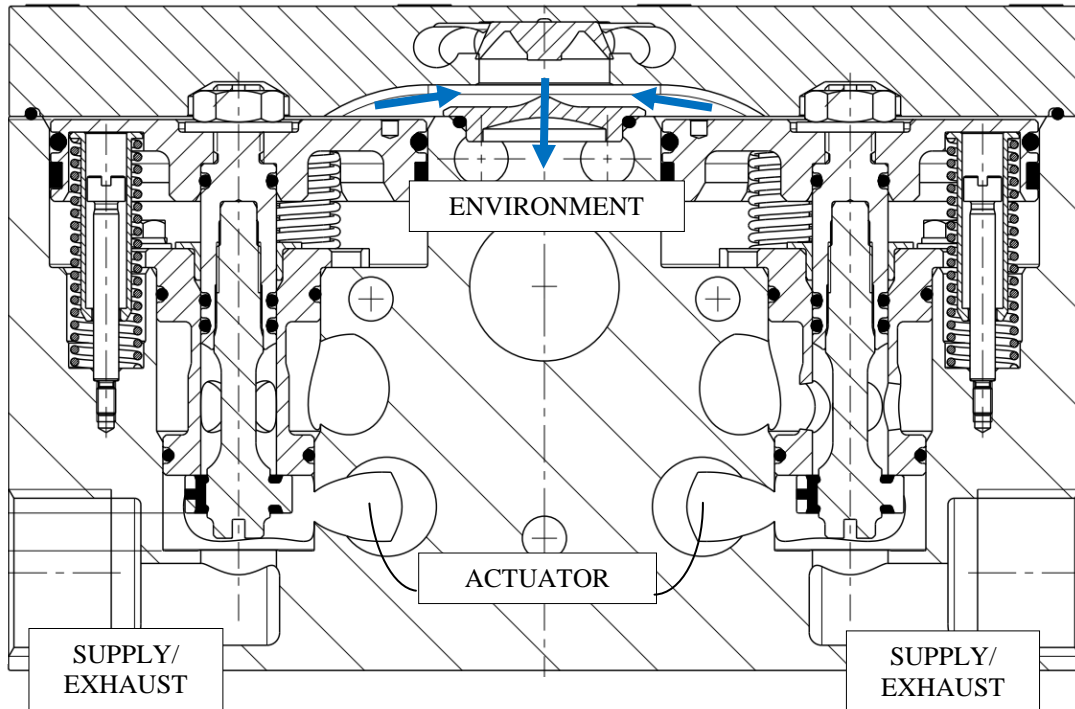
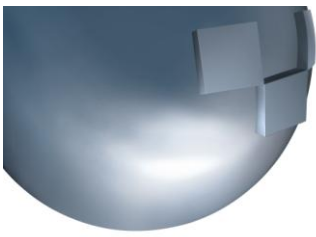

Figure 5 - not energized setup

## 6.2 Intended use

### Warning



**It is severely forbidden to use the CF for purpose or application other than those for which it was designed and here above specified.**

CF is produced by STI S.r.l. (Manufacturer) and identified by a label. STI S.r.l. will not be liable for any possible damage or physical injury resulting from use in other than the designated applications or by lack of care during installation, operation, adjustment and maintenance of the machine. Such risks lie entirely with the user. Depending on the specific working conditions, additional precautions may be requested. Considering that STI S.r.l. has no direct control over particular applications, operation or maintenance conditions, it is the operator's responsibility to comply with all applicable safety rules. Please inform STI S.r.l. urgently if you face unsafe situations not described in this Instruction Manual. It is the sole responsibility of the operator to ensure that the local health and safety regulations are adhered to.

CF is designed in accordance with the applicable International Rules and Specifications, but the following Regulations must be observed in any case:

- the general and safety regulations;
- the plant specific regulations and requirements;
- the proper use of personal and protective devices (glasses, clothing, gloves, etc);
- the proper use of tools and transport equipment.

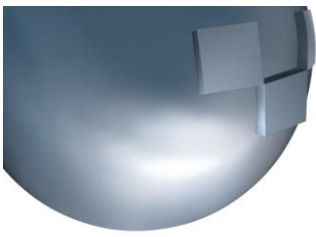

## 6.3 Reasonably foreseeable misuse

A short list of reasonably foreseeable misuse:

- installation in ambient with not planned conditions: i.e. climatic conditions different from the specified conditions;
- Insert incorrect fluid into the system;
- supply pressure out of required range.

## 6.4 Operating limits

<b>Warning</b> 	<b>It is severely forbidden to use the CF under conditions other than those provided on the label.</b>
---	--

The label fastened on the CF contains the main CF operating conditions for the specified application.

## 6.5 Residual Risks

<b>Warning</b> 	<b>The CF has parts under pressure. Use the due caution. Use individual protections provided for by the laws and provisions in force.</b>
---	---

- Risk due to movements of loads during load displacements and assemblage.
- Crushing during assemblage servicing.
- Extreme metal temperature at high (over than 80°C) or very low values as consequence of ambient temperature as to be considered as a risk of person injury in case of contact.
- Emissions of hazardous substances where natural gas is used as motive energy.

## 7 Instructions for the operator

During the start-up of the CF, proceed as follows:

- check that the pressure and quality of the air supply (filtering degree, dehydration) are as prescribed;
- check that there are not leak in the pneumatic connections. If necessary tighten the nuts of the pipe fittings;
- remove all rust and, in accordance with the applicable painting specifications, repair paint-coat that has been damaged during transport, storage or assembly.

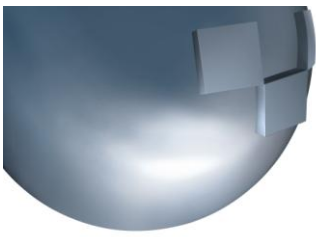

## 8 MAINTENANCE

### 8.1 Periodic Inspections

<p><b>Warning</b></p> 	<p>Take care that a build-up of dust or dirt on the CF can inhibit cooling and contribute to increase surface temperature. The user should plan and provide for a periodic cleaning/maintenance program that will maintain the external surface of the CF free from excessive layer of dust. Operation and maintenance shall be carried out by skilled staff.</p>
---	---

### 8.2 Special maintenance

Under normal condition the CF don't need special maintenance. In case of maintenance send back to STI S.r.l. the device for any repairing and final test.

### 8.3 Repairs

Repairs must not be carried out. When needed send back to STI S.r.l. the device for any repairing and final test.

### 8.4 Reassembling

Disassembling must not be carried out. When needed send back to STI S.r.l. the device for any repairing and final test.

### 8.5 Mechanism Lubrication

RHEOLUBE 361F or equivalent	SYNTHY 101 or equivalent
<p>To be used low temperature conditions (-60°C/+120°C)</p> <p>Color: Light tan Appearance: Smooth NLGI grade: 2 Worked penetration (1/10mm): 265 to 295 ASTM D-2265 Dropping Point: 200°C</p>	<p>To be used in high temperature conditions (-30°C/+200°C)</p> <p>Color: Blue Appearance: Smooth NLGI grade: 2 Worked penetration (1/10mm): 295 ASTM D-2265 Dropping Point: 260°C</p>

<p><b>Important</b></p> 	<p><b>CF does not need lubrication during his life.</b></p>
---	---

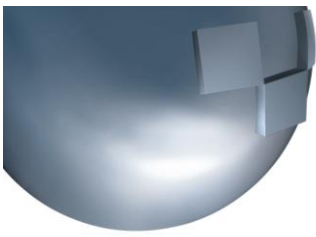

## 9 PARTS LIST GENERAL ASSEMBLY

### 9.1 CF assembly

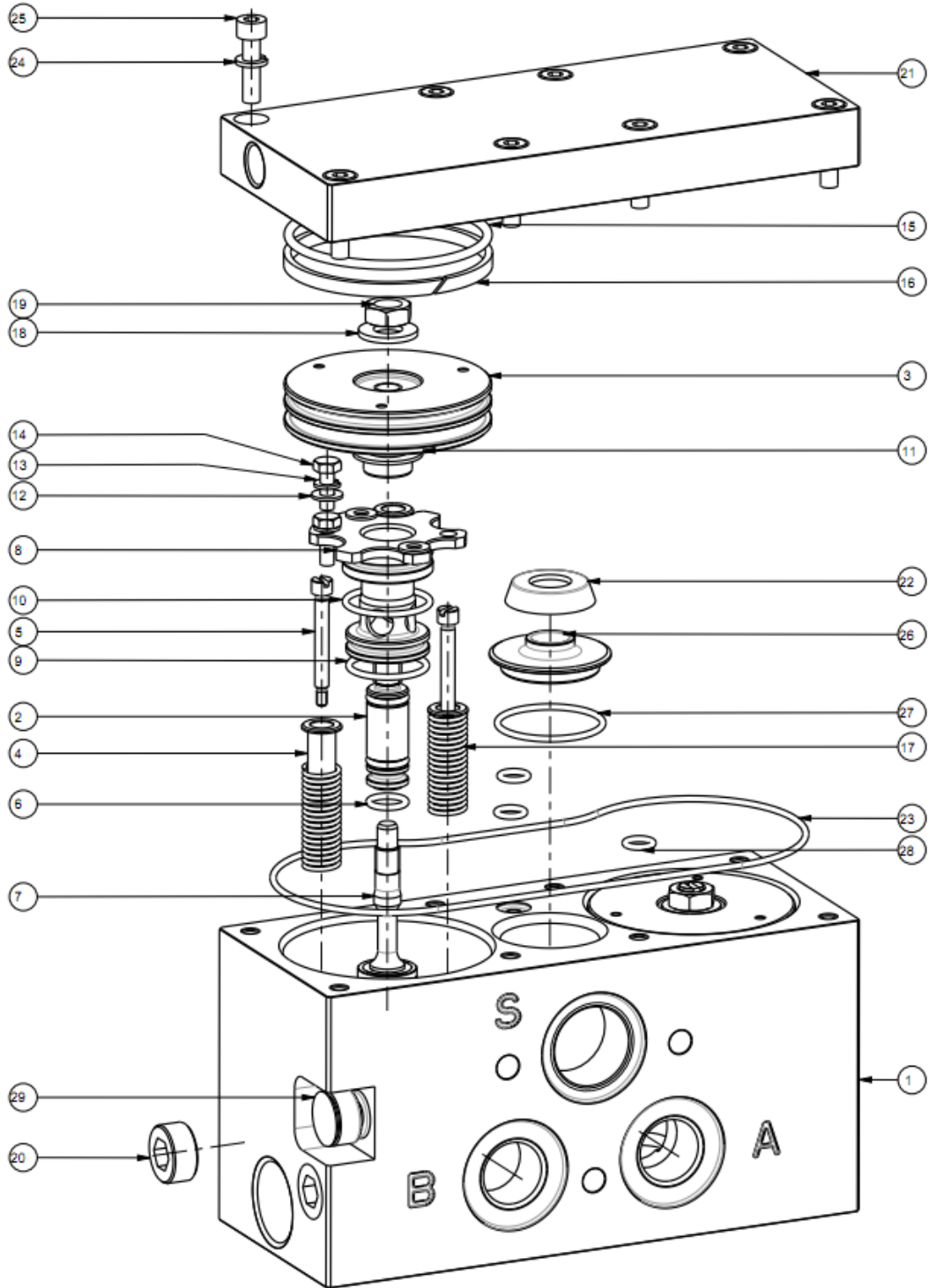



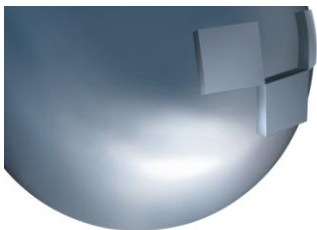

<b>N°</b>	<b>Quantity</b>	<b>Description</b>
1	1	Central body
2	2	Piston stem
3	2	Piston
4	6	Spring guide
5	6	Screw
6	6	Sealing ring OR108
7	2	Shutter stem
8	2	Bushing
9	2	Sealing ring OR2081
10	2	Sealing ring OR2087
11	2	Flange bearing
12	6	Flat washer
13	6	Lock washer
14	6	Screw TE
15	2	Sealing ring OR3212
16	2	Piston sliding ring
17	6	Spring
18	2	Flat washer
19	2	Low nut
20	4	Plug
21	1	Cover
22	1	Diaphragm plugger
23	1	Sealing ring OR2500
24	8	Lock washer
25	8	Screw TCEI
26	1	Quick exhaust seat
27	1	Sealing ring OR2112
28	3	Sealing ring OR2025
29	2	Exhaust

Figure 6 – CF assembly

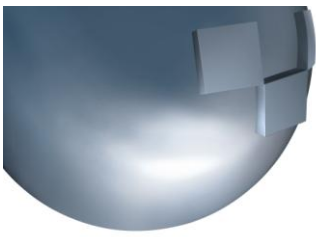

## 10 TROUBLESHOOTING

Valve not shifting completely when energized:

- check to insure that the minimum supply pressure is equal to that shown on the label;
- check for possible restrictions in air supply, such as undersized hoses, fittings or quick disconnects;
- check for proper installation, dirt or damage.

## 11 SPARE PARTS

Repairs must not be carried out. When needed send back to STI S.r.l. the device for any repairing and final test.

## 12 DECOMMISSIONING

Subject	Hazardous	Recyclable	Disposal
Metals	No	Yes	Use licensed recyclers
Plastics	No	Yes	Use specialist recyclers
Rubber (seals and o-rings)	Yes	No	May require special treatment before disposal, use specialist waste disposal companies
Oil and grease	Yes	Yes	May require special treatment before disposal, use specialist waste disposal companies

### Warning



Before starting the disassembly operations it is mandatory to disconnect the pneumatic power and to exhaust the CF. Cylinders chambers, pipe fittings and accessories must not be under pressure. The staff must be qualified for the required operation.

### Warning



The demolition of CF parts should be made from specialized personnel.

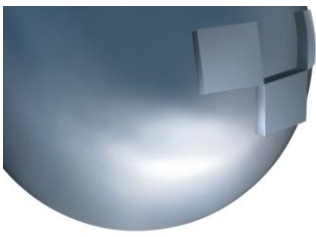

**Important**



**In all cases check local authority regulation before disposal.**

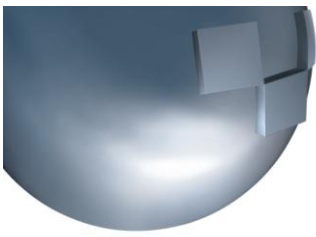

**STI S.r.l.** Via Pascoli 10 a/b  
24020 Gorle (BG) Italy  
Tel. +39 035 2928.2  
Fax +39 035 2928.247  
[info@stistrumentazione.com](mailto:info@stistrumentazione.com)  
[www.stiactuation.com](http://www.stiactuation.com)

